



Product Specification

Ningbo East Electronics Limited
NO. 88 East Jinhui Road, Yinzhou Ningbo 315100, P.R.China
<http://www.east-mingtao.com>

Product Name:	High-Output Piezo Alarm
Part Number:	W-32
Version:	1.03
Date:	2019-10-17
Note:	

East is an ISO 9001 , IATF16949 and ISO 14001 Certified Company

Revision History

Rev.	Description	Author/Date	Checked By	Approver
1.03	Quality management system revised	汤礼东 2019-10-17	吕文斌	王建成
1.02	1.Operation Temperature and Storage Temperature extend to -30°C to 85°C. 2.Add IP standard.	俞凯 2017-1-17	汤礼东	王建成
1.01	Quality Certificate Symbol revised	刘宁 2015-2-12	汤礼东	王建成

1. Part Number W-32

2. Dimension Drawing (Unit: mm)

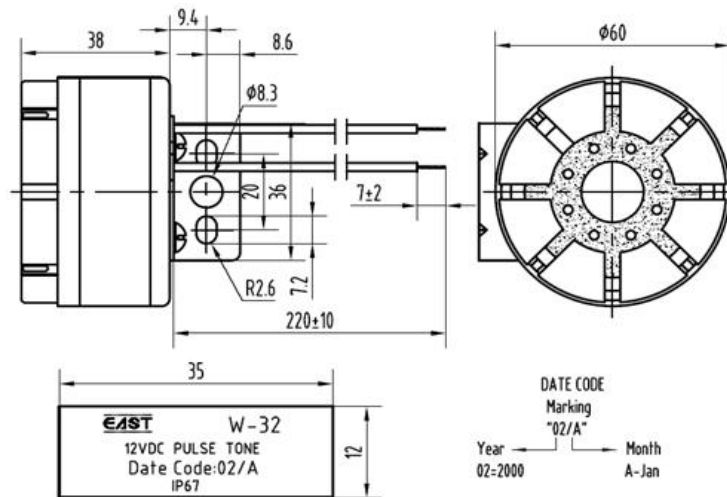

3. Specification

No.	Item	Specification
3-1	Min. Sound Pressure Level	108dB/12V _{DC} /100cm
3-2	Rated Voltage	12V _{DC}
3-3	Operating Voltage	6~15V _{DC}
3-4	Max. Consumption	300mA/12V _{DC}
3-5	Oscillating Frequency	2.8± 0.5kHz
3-6	Tone Nature	Normal Pulse(1.2~1.6Hz)
3-7	Terminal	Lead wire
3-8	Operating Temperature	-30~+85°C
3-9	Case Material/Color	ABS/Black
3-10	Weight	120g
3-11	Wire Standard	UL1007-18AWG
3-12	IP Standard	IP67

NOTES:

Test should be made under the conditions of room temperature (20±10°C), normal humidity (60±20%) and normal atmospheric pressure. In this case, however, that the judgment is questionable, the test conditions are to be changed to room temperature 20±2°C, relative humidity 60~70% and normal atmospheric pressure

4. Typical Frequency Response Curve

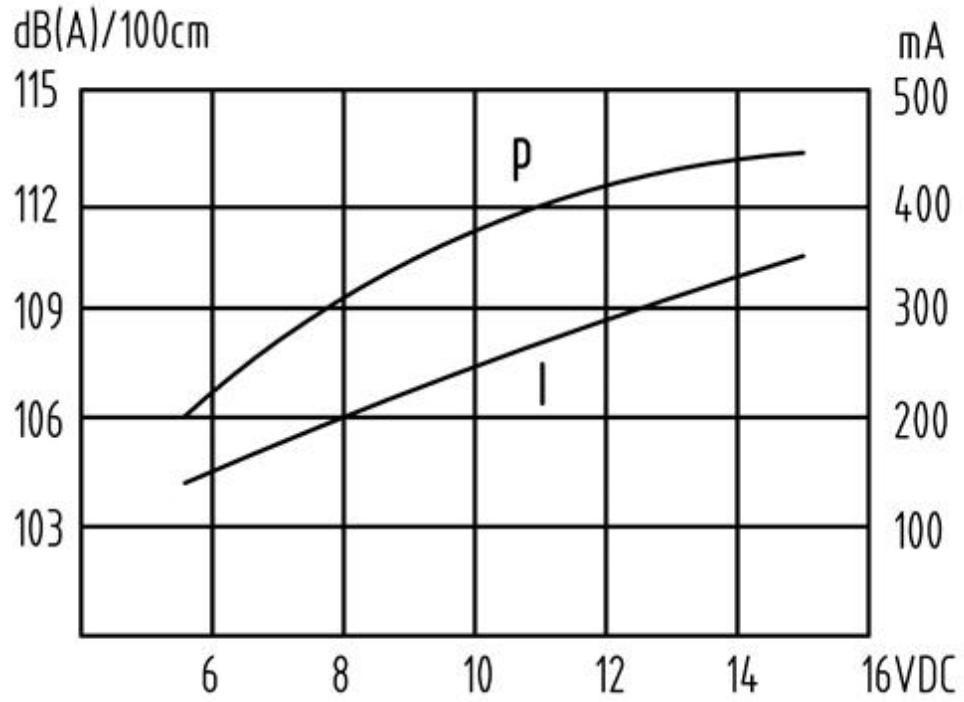

Note:Distance 100 cm

5. Reliability Test

No.	Item	Method of Test	Tolerance after Testing
5-1	Operating Temperature	-20~+85°C	Sound pressure level initial value $\pm 10\text{dB}$ Max. consumption value $\pm 20\%$ Oscillating Frequency Value $\pm 20\%$
5-2	Storage in high temperature	Storage in +85°C test box 96 hours then exposed to the room temperature for 2 hours	
5-3	Storage in low temperature	Storage in -20°C test box 96 hours then exposed to the room temperature for 2 hours	
5-4	Life test in the room temperature	Operate the product continuously 5 seconds on 5 seconds off 96 hours at rated voltage	
5-5	Temperature / humidity cycle test	Storage in +40°C, 93 \pm 3%RH test box 96 hours then exposed to the room temperature for 2 hours	
5-6	Temperature (high and low) cycle test	Conduct the test for 5 cycles without applying power then expose to the room temperature for 2 hours.(See Figure 5-6)	
5-7	Vibration test	Conduct the test for the directions of X Y and Z for 0.5 hour each (total 1.5 hours). To-and Fri sweep time(from 10 to 55Hz and then 55 to 10) under single amplitude of 0.75mm is 3 minute, then expose to the room temperature for 2 hours	
5-8	Drop test	Drop a product naturally from the height of 700mm onto the surface of 100mm thick wooden board. Two directions: upper and side of the product are to be applied for this drop test once respectively	

Figure 5-6

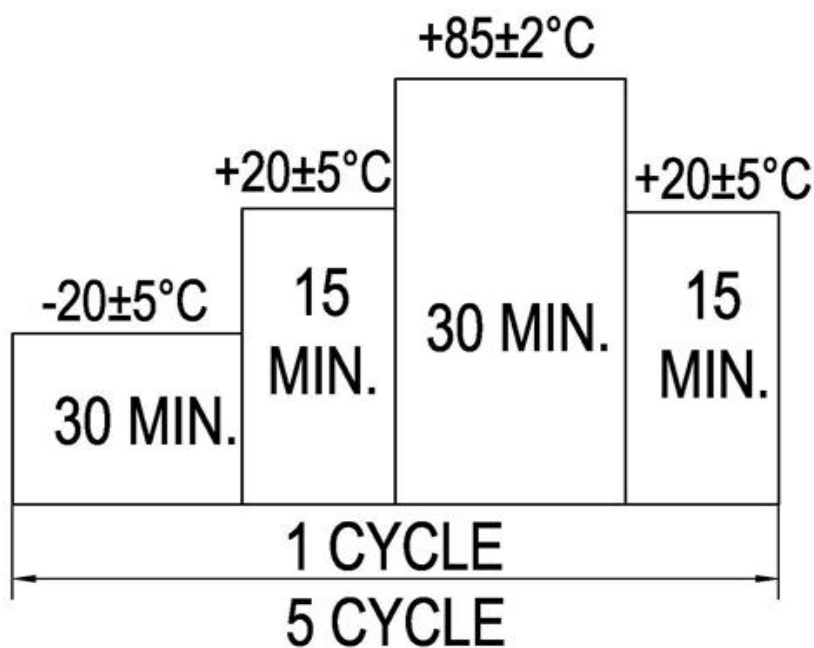

6. Electrical Testing Method

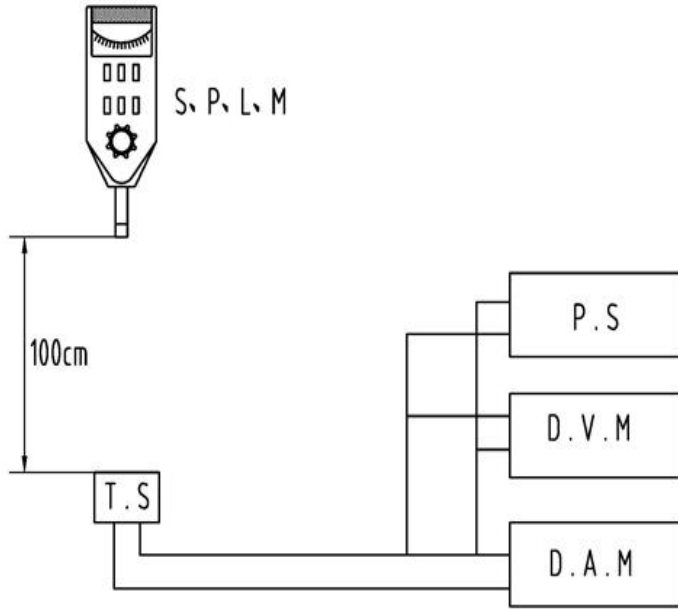

S.P.L.M	Sound Pressure Level Meter
T.S	Testing Sample
P.S	Power Supply
D.V.M	DC Voltage Meter
D.A.M	DC Ampere Meter

7. Packing Information

Packing: 120 pcs per export carton

Carton Size: 47× 30.5× 21 cm

G. Weight: 16 kgs N. Weight: 14.4 kgs