



# Product Specification

**Ningbo East Electronics Limited**  
NO. 88 East Jinhui Road, Yinzhou Ningbo 315100, P.R.China  
<http://www.east-mingtao.com>

Product Name:	Piezo Buzzer
Part Number:	FM-24D-900
Version:	1.02
Date:	2019-8-20
Note:	

**East is an ISO 9001 , IATF16949 and ISO 14001 Certified Company**

## Revision History

Rev.	Description	Author/Date	Checked By	Approver
1.02	Quality management system revised	汤礼东 2019-8-20	吕文斌	王建成
1.01	Quality Certificate Symbol revised	吕文斌 2015-2-12	汤礼东	王建成
1.0	Released	陈启旺 2012-4-2	汤礼东	王建成

## 1. Part Number FM-24D-900

## 2. Dimension Drawing (Unit: mm)

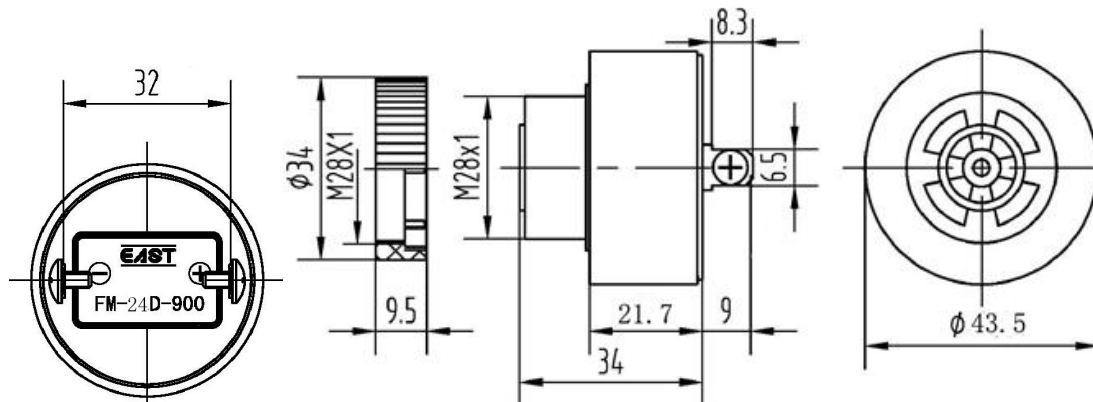

## 3. Specification

No.	Item	Specification
3-1	Min. Sound Pressure Level	85dB/24V <sub>DC</sub> /30cm
3-2	Rated Voltage	24V <sub>DC</sub>
3-3	Operating Voltage	4~ 28V <sub>DC</sub>
3-4	Max. Consumption	22mA/24V <sub>DC</sub>
3-5	Oscillating Frequency	2.9±0.5 kHz
3-6	Tone Nature	Continuous
3-7	Operating Temperature	-20~+70°C
3-8	Case Material/Color	ABS/Black
3-9	Weight	43g
3-10	Pin Strength	More than 10N

### NOTES:

1. This series is epoxy-potting type.
2. Test should be made under the conditions of room temperature (20±10°C), normal humidity (60±20%) and normal atmospheric pressure. In this case, however, that the judgment is questionable, the test conditions are to be changed to room temperature 20±2°C, relative humidity 60~70% and normal atmospheric pressure

#### 4. Typical Frequency Response Curve

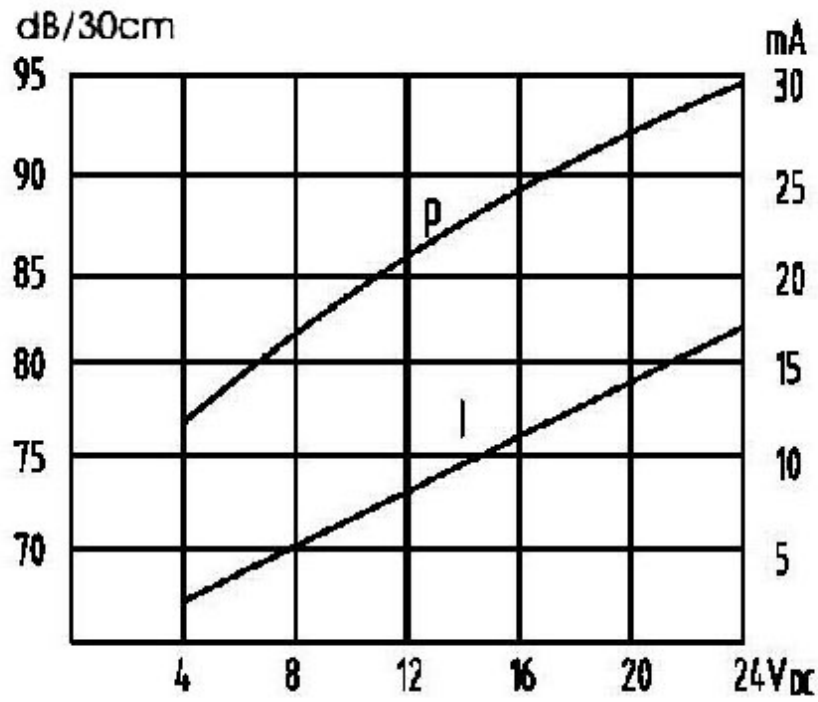

**Note:**Distance 30 cm

## 5. Reliability Test

No.	Item	Method of Test	Tolerance after Testing
5-1	Operating Temperature	-20~+70°C	Sound pressure level initial value $\pm 10\text{dB}$ Max. consumption value $\pm 20\%$ Oscillating frequency value $\pm 20\%$
5-2	Storage in high temperature	Storage in +70°C test box 96 hours then exposed to the room temperature for 2 hours	
5-3	Storage in low temperature	Storage in -20°C test box 96 hours then exposed to the room temperature for 2 hours	
5-4	Life test in the room temperature	Operate the product continuously 5 seconds on 5 seconds off 300 hours at rated voltage	
5-5	Temperature / humidity cycle test	Storage in +40°C, 93 $\pm$ 3%RH test box 96 hours then exposed to the room temperature for 2 hours	
5-6	Temperature (high and low) cycle test	Conduct the test for 5 cycles without applying power then expose to the room temperature for 2 hours.(See Figure 5-6)	
5-7	Vibration test	Conduct the test for the directions of X Y and Z for 0.5 hour each (total 1.5 hours). To-and Fri sweep time(from 10 to 55Hz and then 55 to 10) under single amplitude of 0.75mm is 3 minute, then expose to the room temperature for 2 hours	
5-8	Drop test	Drop a product naturally from the height of 700mm onto the surface of 100mm thick wooden board. Two directions: upper and side of the product are to be applied for this drop test once respectively	

Figure 5-6

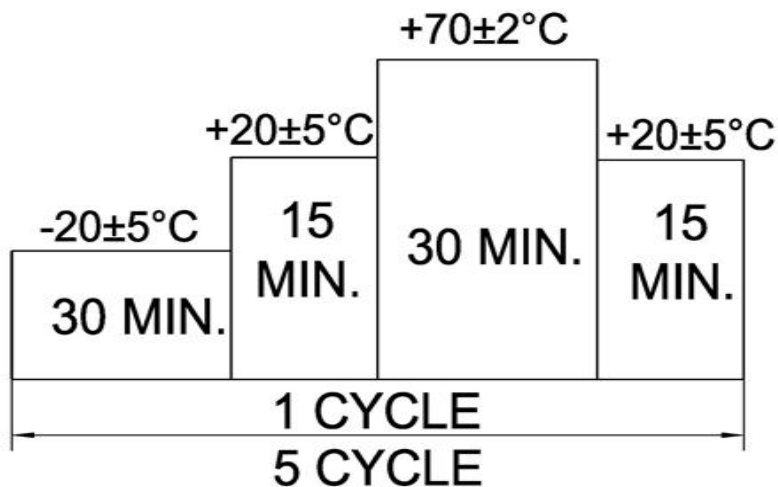

## 6. Electrical Testing Method

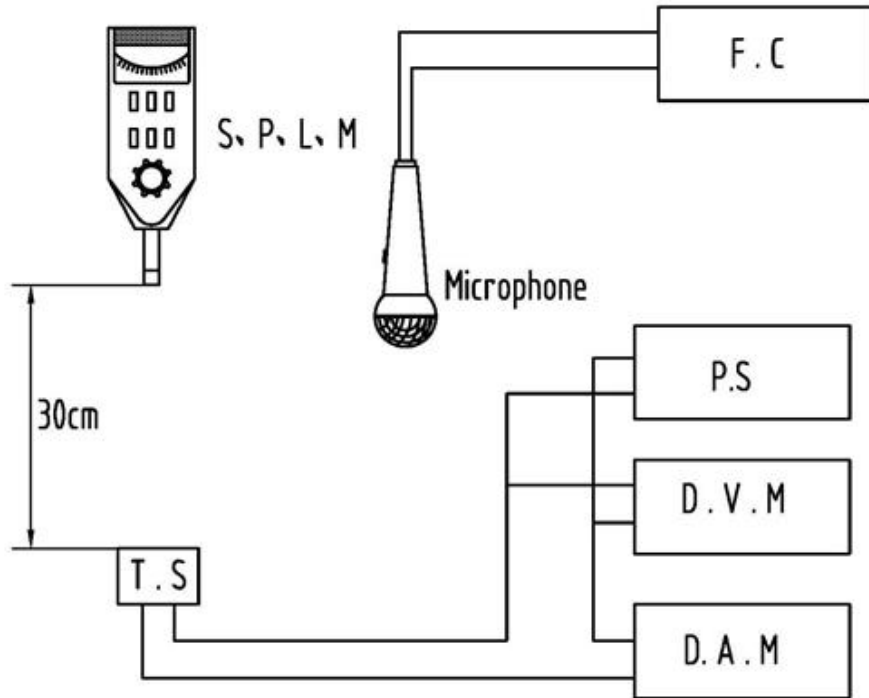

S.P.L.M	Sound Pressure Level Meter
T.S	Testing Sample
F.C	Frequency Counter
P.S	Power Supply
D.V.M	DC Voltage Meter
D.A.M	DC Ampere Meter

## 7. Packing Information

**Packing: 200 pcs per export carton**

**Carton Size: 47× 30.5× 29 cm**

**G. Weight: 10.2 kgs N. Weight: 8.6 kgs**