



Product Specification

Ningbo East Electronics Limited
NO. 88 East Jinhui Road, Yinzhou Ningbo 315100, P.R.China
<http://www.east-mingtao.com>

| | |
|---------------|-----------------------------------|
| Product Name: | External -Driven Piezo Transducer |
| Part Number: | TFM-25F |
| Version: | 1.02 |
| Date: | 2019-9-6 |
| Note: | |

East is an ISO 9001 , IATF16949 and ISO 14001 Certified Company

Revision History

| Rev. | Description | Author/Date | Checked By | Approver |
|------|------------------------------------|------------------|------------|----------|
| 1.02 | Quality management system revised | 汤礼东 2019-9-6 | 吕文斌 | 王建成 |
| 1.01 | Quality Certificate Symbol revised | 刘宁 2015-2-12 | 汤礼东 | 王建成 |
| 1.0 | Released | 汤礼东 2011-7-11 | 张春雷 | 王建成 |

1. Part Number TFM-25F

2. Dimension Drawing (Unit: mm)

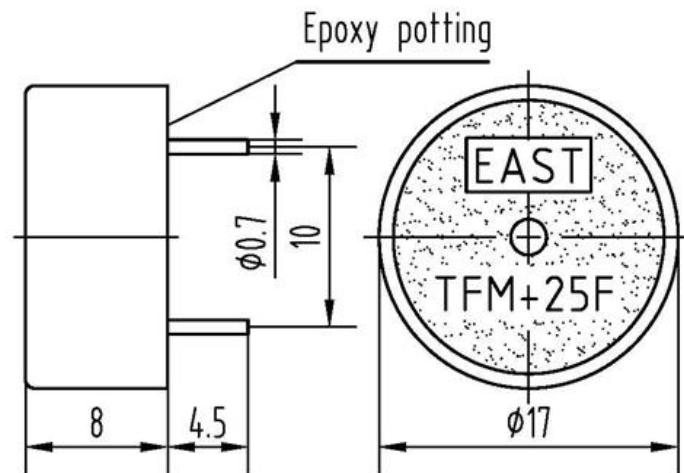

3. Specification

| No. | Item | Specification |
|-----|---------------------------|-------------------------------------|
| 3-1 | Min. Sound Pressure Level | 70dB/2.0kHz/3Vp-p square wave /10cm |
| 3-2 | Allowed Input Voltage | 25Vp-p |
| 3-3 | Capacitance | 28±30% nF (At 120Hz) |
| 3-4 | Max. Consumption | 3mA/2.0kHz/3Vp-p square wave |
| 3-5 | Resonant Frequency | 2.0± 0.5kHz |
| 3-6 | Operating Temperature | -20~+70°C |
| 3-7 | Case Material /Color | PA6/Black |
| 3-8 | Weight | 1.4g |
| 3-9 | Pin Strength | More than 10N |

NOTES:

Test should be made under the conditions of room temperature (20±10°C), normal humidity (60±20%) and normal atmospheric pressure. In this case, however, that the judgment is questionable, the test conditions are to be changed to room temperature 20±2°C, relative humidity 60~70% and normal atmospheric pressure

4. Typical Frequency Response Curve

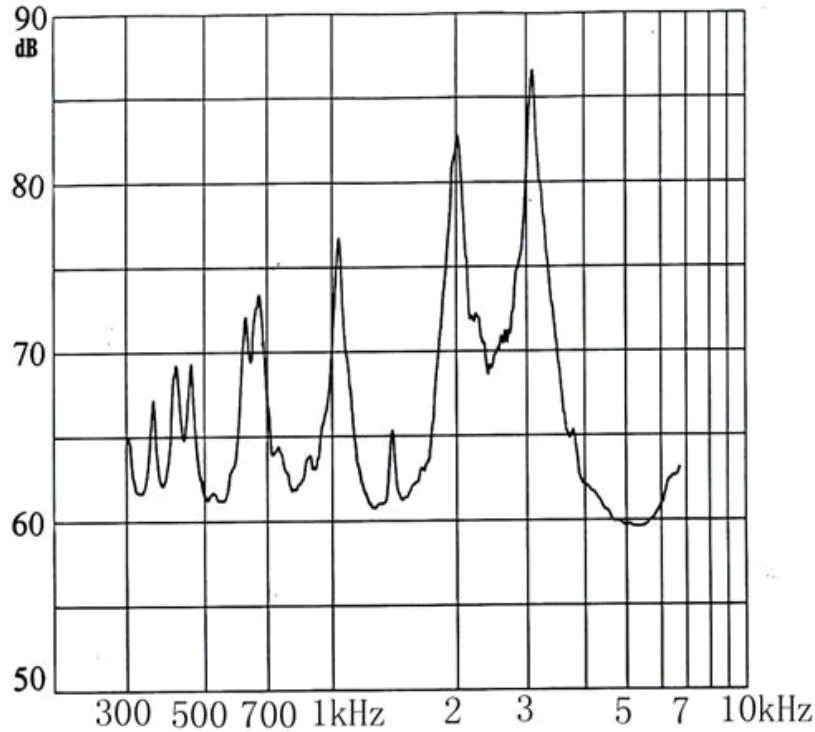

Note: Input Voltage 3Vp-p square wave
Distance 10 cm

5. Reliability Test

| No. | Item | Method of Test | Tolerance after Testing |
|-----|---------------------------------------|---|---|
| 5-1 | Operating Temperature | -20~+70°C | Sound pressure level initial value ± 10 dB Max. consumption value $\pm 20\%$ Capacitance value $\pm 20\%$ |
| 5-2 | Storage in high temperature | Storage in +70°C test box 96 hours then exposed to the room temperature for 2 hours | |
| 5-3 | Storage in low temperature | Storage in -20°C test box 96 hours then exposed to the room temperature for 2 hours | |
| 5-4 | Life test in the room temperature | Operate the product continuously 5 seconds on 5 seconds off 300 hours at rated voltage | |
| 5-5 | Temperature / humidity cycle test | Storage in +40°C, 93 \pm 3%RH test box 96 hours then exposed to the room temperature for 2 hours | |
| 5-6 | Temperature (high and low) cycle test | Conduct the test for 5 cycles without applying power then expose to the room temperature for 2 hours.(See Figure 5-6) | |

| | | | |
|--|--------------------------------|--|--|
| 5-7 | Vibration test | Conduct the test for the directions of X Y and Z for 0.5 hour each (total 1.5 hours). To-and Fri sweep time(from 10 to 55Hz and then 55 to 10) under single amplitude of 0.75mm is 3 minute, then expose to the room temperature for 2 hours | |
| 5-8 | Drop test | Drop a product naturally from the height of 700mm onto the surface of 100mm thick wooden board. Two directions: upper and side of the product are to be applied for this drop test once respectively | |
| 5-9 | Soldering heat resistance test | Dip the connecting pins in soldering at $260\pm 5^{\circ}\text{C}$ for 10 ± 1 seconds | |
| 5-10 | Test of soldering | Dip the connecting pins in soldering at $230\pm 5^{\circ}\text{C}$ for 3 ± 0.5 seconds | Solder shall be attached around over 95% of the dipped portion |
| NOTE: The pins are allowed to deform after drop test. | | | |

Figure 5-6

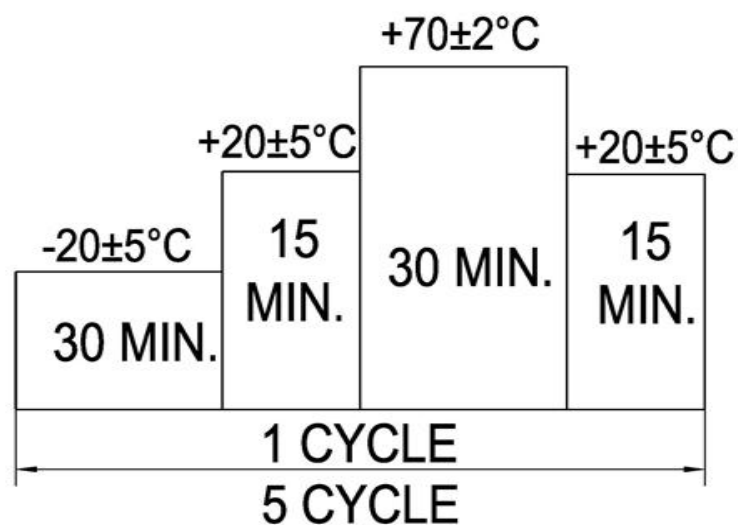

6. Electrical Testing Method

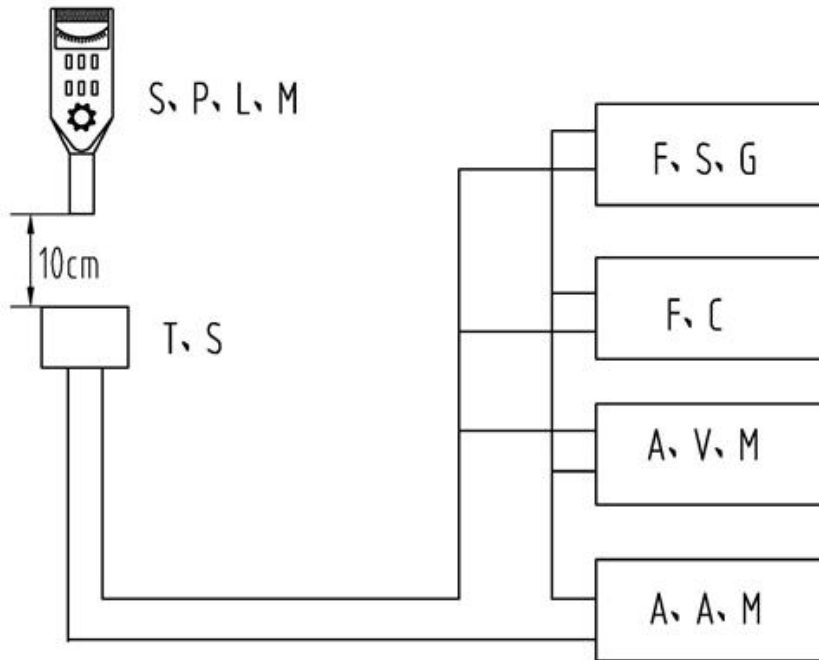

| | |
|---------|----------------------------|
| S.P.L.M | Sound Pressure Level Meter |
| T.S | Testing Sample |
| F.C | Frequency Counter |
| F.S.G | Frequency Signal Generator |
| A.V.M | AC Voltage Meter |
| A.A.M | AC Ampere Meter |

7. Packing Information

Packing: 3000 pcs per export carton

Carton Size: 47× 30.5× 27 cm

G. Weight: 5.8 kgs N. Weight: 4.2 kgs