



Product Specification

Ningbo East Electronics Limited

NO. 88 East Jinhui Road, Yinzhou Ningbo 315100, P.R. China

<http://www.east-mingtao.com>

Product Name:	Sound box
Part Number:	SED-40L8.5-4N3RHC-1 (4Ω 3W)
Version:	Rev. 3
Date:	2017-11-18
Note:	

Company passed ISO 9001 / ISO TS16949 / ISO 14001 Certifications

Revision History

Rev.	Description	Author/Date	Checked By	Approver
1	Released	Lv Wenbin Nov. 20. 2015	Zhao Pengsen	Wang Jiancheng
2	M1:Modification SPL	Lv Wenbin Dec. 10. 2015	Zhao Pengsen	Wang Jiancheng
3	Change the company name to East Electronics	SYSTEM Nov. 18. 2017		

1. Part Number : SED-40L8.5-4N3RHC-1

2. Dimension Drawing: (Unit: mm)

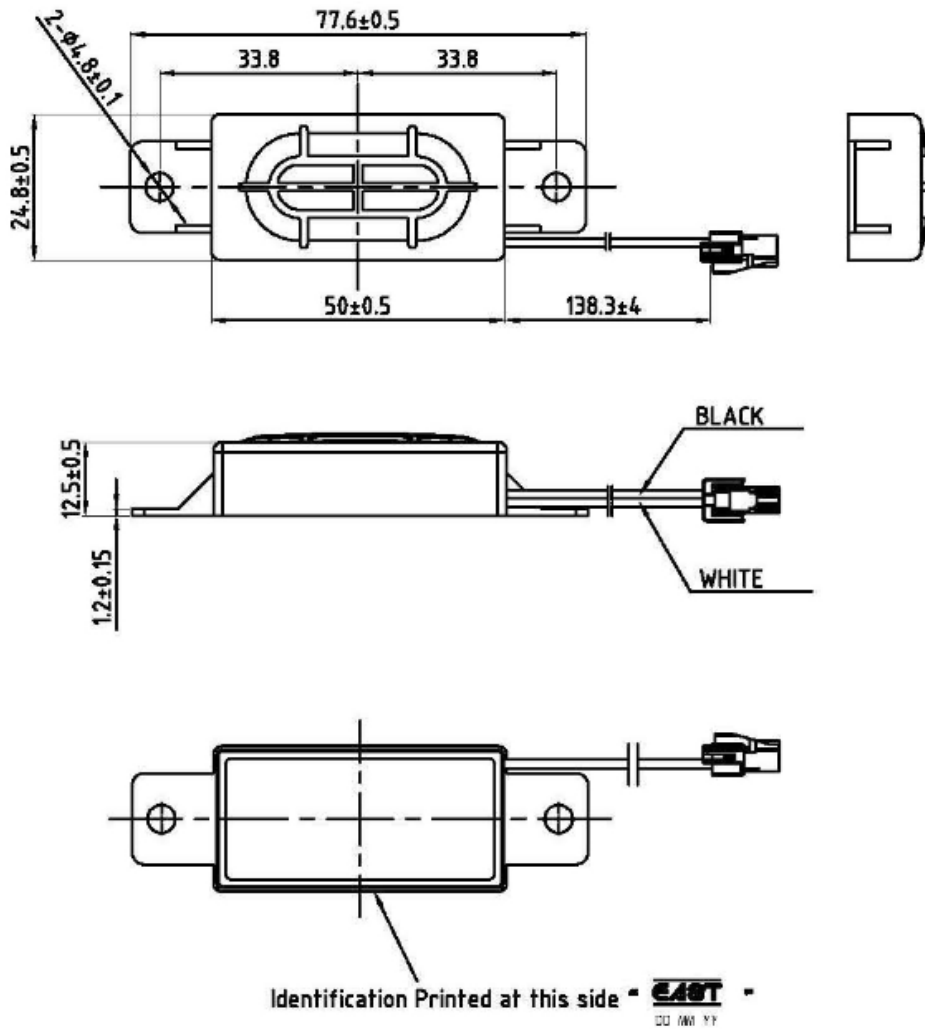

Connector housing	JST PARP-02V
Connector retainer	JST PMS-02V-S
Connector terminal	JST SPA-001T-P0.5
Wire	UL1007-24AWG

3. Specification:

No.	Items	Specification
3-1	Rated impedance	4Ω ± 15 % at 2.0kHz
3-2	SPL normal power input M1	92± 3 dB 0.3M / 1W (1.6K,1.8K,2.0K,2.2KHz average) 2.0V
3-3	Frequency range	800Hz ~ 20kHz SPL-10dB 2.0V
3-4	Distortion	< 10 % at 1kHz 2.0V
3-5	Normal power	3.0 W @ Rated noise power operating continuously for 100 hours 3.46V
3-6	Maximum power	4.0 W @ Stimulant program signal for 1 min. on & 2 min. off, cycling for 10 times 4.0V
3-7	Appearance normal	@ A.T. 15~35°C, H.M. 25~75%, B.P. 86~106kPa
3-8	Buzzes & rattles no appearance	@ 0.3m with sine wave from 500Hz to 20kHz input/rated noise power 2.91V
3-9	Diaphragm material	Waterproof membrane
3-10	Weight	15g

NOTES :

1. Test in anechoic room and use the IEC standard baffle which size at : 1350 mm (W) X 1650 mm (H)
2. Test should be made under the conditions of room temperature (20 ±10 °C), relative humidity (60 ±20%) and normal atmospheric pressure. In this case, however, that the judgment is questionable, the test conditions are to be changed to room temperature 20 ±2 °C, relative humidity 60~70% and normal atmospheric pressure.

4. Typical Frequency Response Curve:

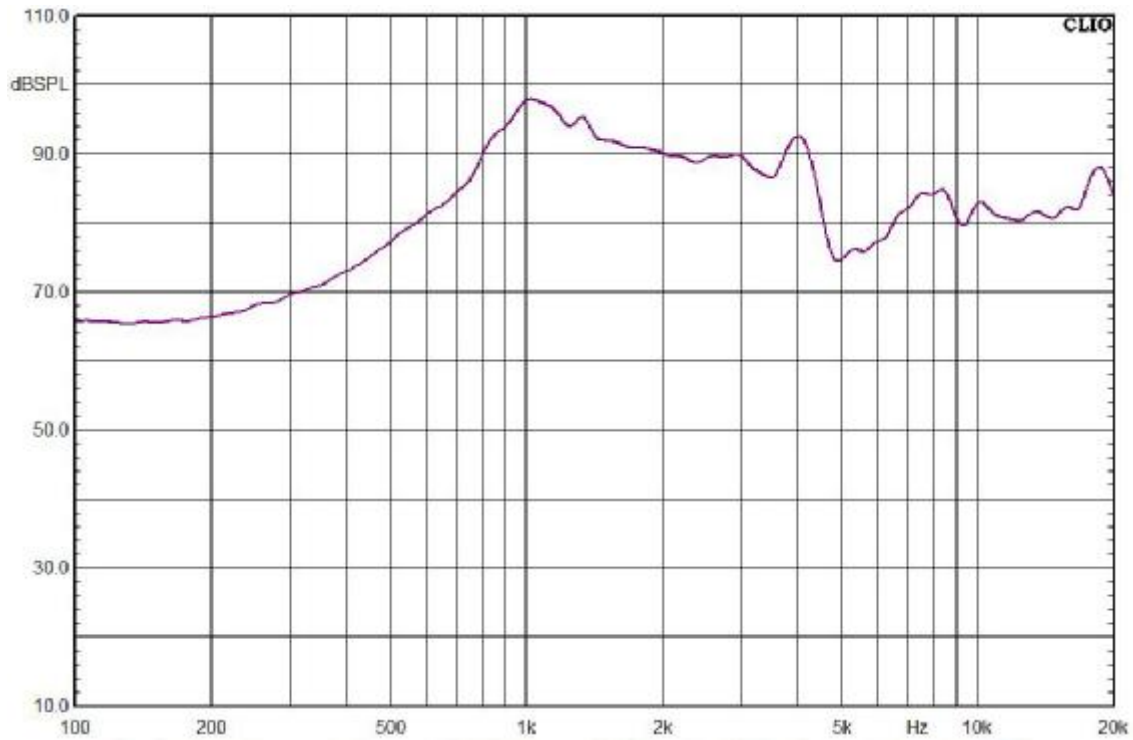

5. Reliability Test:

No.	Item	Method of Test	Tolerance after Testing
5-1	Operating temperature	-25 °C ~ +85 °C	
5-2	High-temperature loading & storage	@ ¼ rated noise power /85 ± 2 °C operating for 16 hours then depositing for 2 hours at constant temperature, completing testing within 1 hour after withdrawing.	Meet requirements of appearance, Buzzes & rattles after test
5-3	Low-temperature loading & storage	@ ¼ rated noise power/-10 ± 3 °C operating for 1 hours, depositing @ -25 ± 3 °C for 2 hours, then resuming at normal atmosphere conditions (GB/T9396-1996 4.2) for 4 hours.	Meet requirements of appearance, Buzzes & rattles, solderability after test
5-4	Static humidity /temperature	@ A.T. 40 ± 2 °C, H.M.93± 2 % depositing for 48 hours, then resuming @ normal atmosphere conditions (GB/T9396-1996 4.2) for 24 hours.	Meet requirements of appearance, Buzzes & rattles, insulation resistance, bearing voltage after test
5-5	Temperature (high and low) cycle test	Storage in -25 °C ± 5 °C for 2 hours, in 20 °C ± 5 °C for 2 hours, in 85°C ± 5 °C for 2 hours then back in 20 °C ± 5 °C 2 hours, as one cycle. 12 cycle in total.	Appearance: no obviously damage Tone: no obviously noise
5-6	Drop test	Drop a product naturally from the height of 1000 mm onto the surface of 100 mm thick wooden board. Two directions: upper and side of the product are to be applied for this drop test once respectively.	
5-7	Life test in the room temperature	Input the signal with the valid frequency range on the speaker in continuously for 100 hours, the room temperature should control in 15 °C to 35 °C.	
5-8	Vibration test	Conduct the test for the directions of X Y and Z for 0.5 hour each (total 1.5 hours). To-and Fri sweep time(from 10 to 55 Hz and then 55 to 10) under single amplitude of 0.75 mm is 3 minute, then expose to the room temperature for 2 hours.	SPL ±3dB F0 ±20% ACR ±15%

NOTE: The frame is allowed to deform after drop test.

6. Electrical Testing Method:

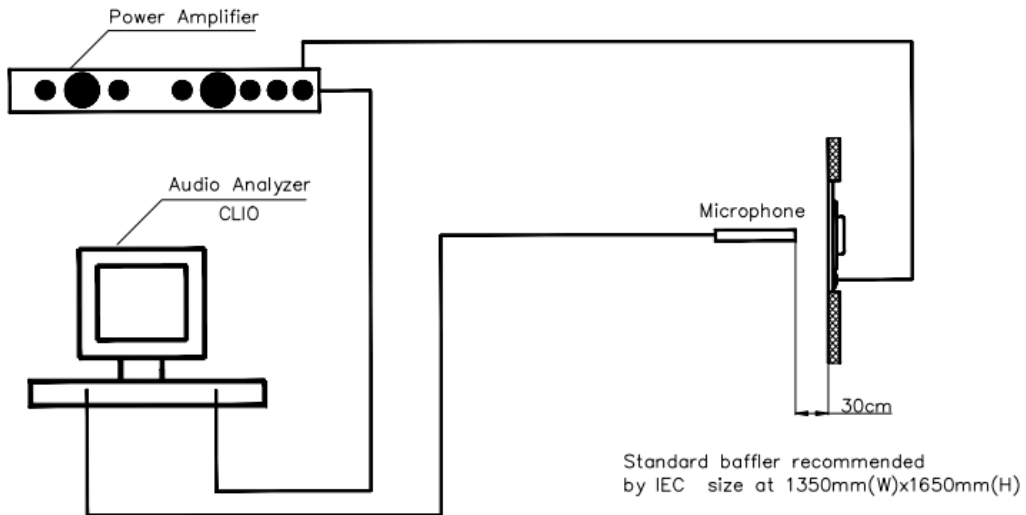

7. Packing Information:

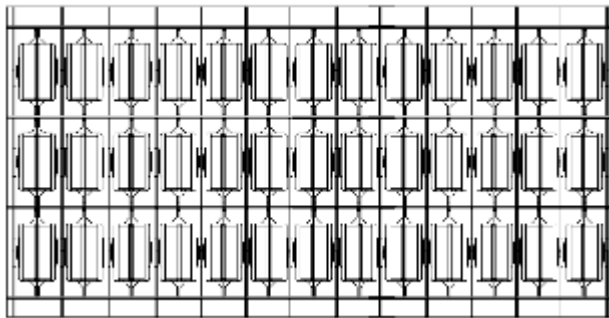

Crosswise card

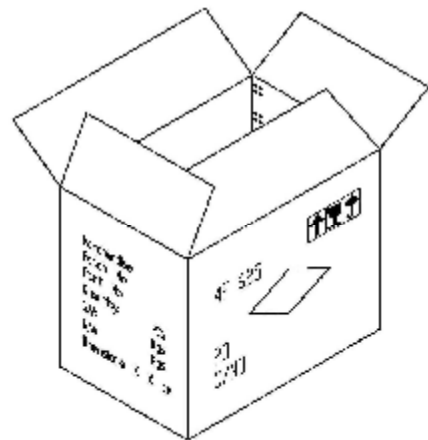

Shipping carton

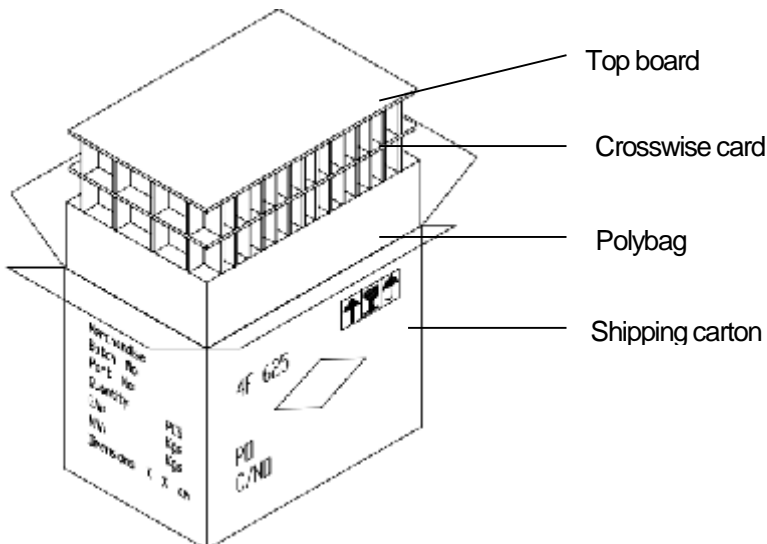

Packing information:

1. Packing: 780 pcs per export carton
2. Carton Size: 47×30.5× 35 cm
3. N.W:11.7kg G.W:14kg